

**OXFORD CAMBRIDGE AND RSA EXAMINATIONS  
GCSE**

**J567/03**

**MATHEMATICS B**

**Paper 3 (Higher Tier)**

**WEDNESDAY 6 NOVEMBER 2013: Morning**

**DURATION: 1 hour 45 minutes  
plus your additional time allowance**

**MODIFIED ENLARGED**

<b>Candidate forename</b>		<b>Candidate surname</b>	
-------------------------------	--	------------------------------	--

<b>Centre number</b>						<b>Candidate number</b>				
--------------------------	--	--	--	--	--	-----------------------------	--	--	--	--

**Candidates answer on the Question Paper.**

**OCR SUPPLIED MATERIALS:**

**None**

**OTHER MATERIALS REQUIRED:**

**Geometrical instruments  
Tracing paper (optional)**

<p style="text-align: center;"><b><u>WARNING</u></b> <b>NO CALCULATOR CAN BE USED FOR THIS PAPER</b></p>
--

**READ INSTRUCTIONS OVERLEAF**

## **INSTRUCTIONS TO CANDIDATES**

- **Write your name, centre number and candidate number in the boxes on the first page. Please write clearly and in capital letters.**
- **Use black ink. HB pencil may be used for graphs and diagrams only.**
- **Answer ALL the questions.**
- **Read each question carefully. Make sure you know what you have to do before starting your answer.**
- **Your answers should be supported with appropriate working. Marks may be given for a correct method even if the answer is incorrect.**
- **Write your answer to each question in the space provided. Additional paper may be used if necessary but you must clearly show your candidate number, centre number and question number(s).**

## **INFORMATION FOR CANDIDATES**

- **The number of marks is given in brackets [ ] at the end of each question or part question.**
- **Your quality of written communication is assessed in questions marked with an asterisk (\*).**
- **The total number of marks for this paper is 100.**

**BLANK PAGE**

# FORMULAE SHEET: HIGHER TIER

Area of trapezium =  $\frac{1}{2}(a + b)h$

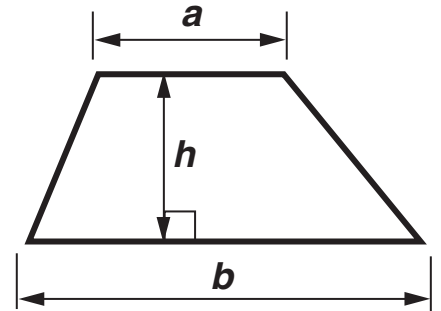

Volume of prism = (area of cross-section)  $\times$  length

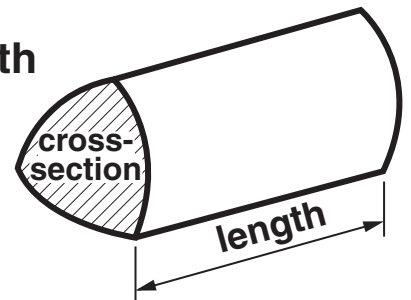

In any triangle *ABC*

Sine rule  $\frac{a}{\sin A} = \frac{b}{\sin B} = \frac{c}{\sin C}$

Cosine rule  $a^2 = b^2 + c^2 - 2bc \cos A$

Area of triangle =  $\frac{1}{2}ab \sin C$

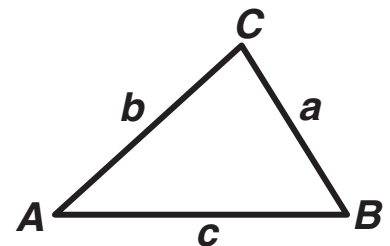

Volume of sphere =  $\frac{4}{3}\pi r^3$

Surface area of sphere =  $4\pi r^2$

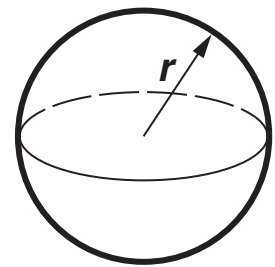

**Volume of cone =  $\frac{1}{3}\pi r^2 h$**

**Curved surface area of cone =  $\pi r l$**

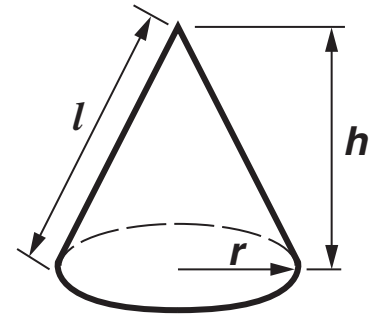

**The Quadratic Equation**

**The solutions of  $ax^2 + bx + c = 0$ ,  
where  $a \neq 0$ , are given by**

$$x = \frac{-b \pm \sqrt{b^2 - 4ac}}{2a}$$

**Answer ALL the questions.**

**1 (a) Written as the product of its prime factors,  
 $108 = 2^2 \times 3^3$ .**

**(i) Write 96 as the product of its prime factors.**

**(a)(i) \_\_\_\_\_ [2]**

**(ii) Find the highest common factor of 96 and 108.**

**(ii) \_\_\_\_\_ [2]**

**(b) Work out.**

$$1\frac{3}{4} + 3\frac{5}{12}$$

**Give your answer as a mixed number in its simplest form.**

**(b) \_\_\_\_\_ [3]**

**2 (a) Complete the following two sentences.**

**The negative square root of 49 is**

\_\_\_\_\_.

**5 is the cube root of \_\_\_\_\_.** [2]

**(b) Work out the value of  $2b^2 - b$  when  $b = -3$ .**

**(b) \_\_\_\_\_** [2]



- 3 (a) Felix wants to work out how much it costs him to use his tumble dryer.  
The tumble dryer uses 1.9 units of electricity to dry one load of washing.  
Felix dries four loads of washing each week.  
He pays 12.8 p for every unit of electricity he uses.**

**Work out the weekly cost, in pence, of using the tumble dryer.**

**(a) \_\_\_\_\_ p [4]**

**(b) Felix reads the electricity meter in his house each week.**

**Here is his record of the number of units he has used each week for 16 weeks.**

**74    73    86    78    70    74    73    60**  
**64    67    49    77    53    68    57    54**

**(i) Complete the following stem and leaf diagram to represent this data. [3]**

<b>4</b>	
<b>5</b>	
<b>6</b>	
<b>7</b>	
<b>8</b>	

**Key: 7|4 represents 74**

- (ii) Felix reads in a newspaper article that the average household uses 330 units of electricity each month.**

**How does the electricity he uses compare with this figure?**

**Support your answer using Felix's data.**

---

---

---

---

---

---

---

---

**[4]**

- 4\* In the diagram below ADE is a triangle.  
BC is parallel to DE and DBA is parallel to EF.

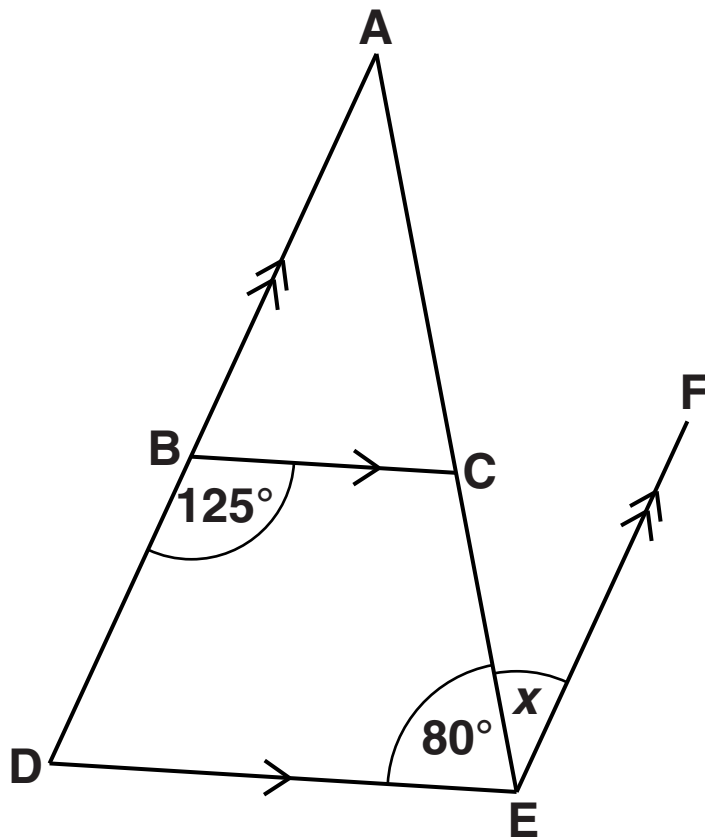

NOT TO SCALE

Work out angle  $x$ .  
Give a reason for each step of your working. [5]

- 5 (a) Wanda asked a random sample of 120 students from a college what they were planning to do when they left college. The following table shows the results of Wanda's survey.

University	Apprenticeship	Job
74	16	30

- (i) One of these students is selected at random.

What is the probability that the student is planning to go to university?

(a)(i) \_\_\_\_\_ [1]

- (ii) There are 2400 students at the college.

Estimate the number of these students who plan to get a job.

(ii) \_\_\_\_\_ [2]

**(b) Wanda plans to interview some of the students in more detail.**

**Of the 2400 students, 1500 are male and 900 are female.**

**She decides to interview a representative stratified sample of 80 students.**

**How many male students should she interview?**

**(b) \_\_\_\_\_ [2]**

6 (a) Solve this inequality.

$$3x - 4 \leq 8$$

(a) \_\_\_\_\_ [2]

(b) Represent your solution on the number line below. [1]

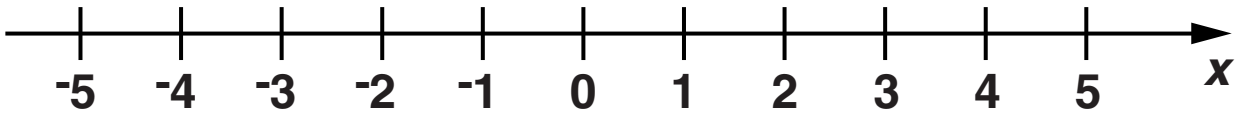

- 7 A floor is tiled using a pattern of two different shaped tiles.  
One of the shapes is a square and the other is a regular polygon.**

**At each vertex in the pattern, two of the polygon tiles and one square tile meet. This is shown on the following diagram.**

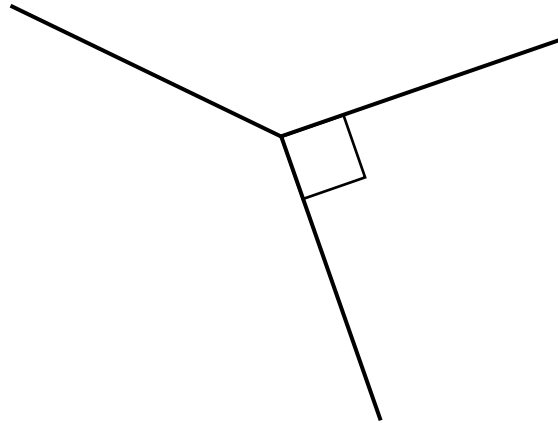

**What shape is the regular polygon?  
Show your reasoning clearly.**

---

---

---

**[4]**



**BLANK PAGE**

8 Triangles A and C are drawn on the grid below.

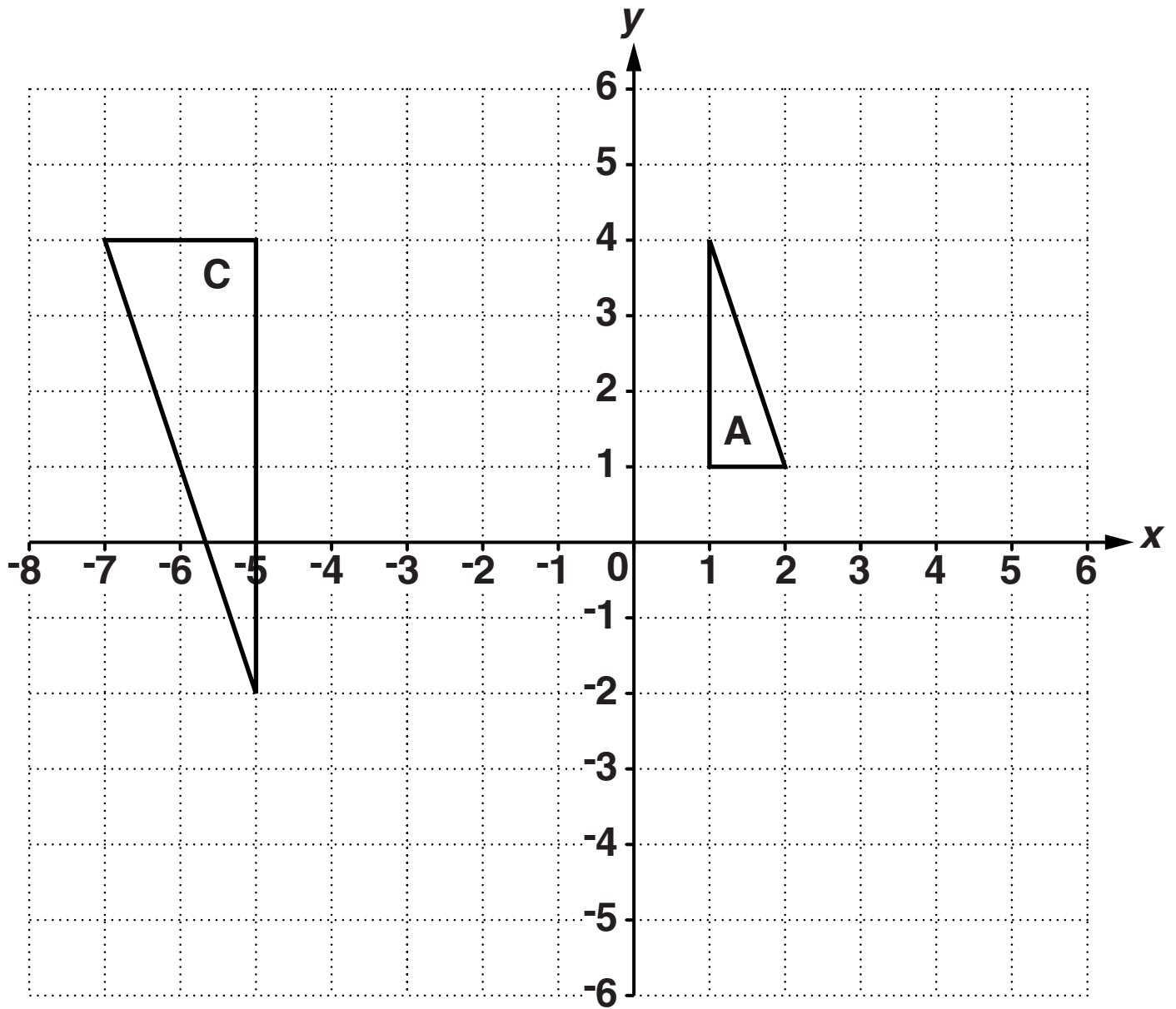

**(a) Triangle B is the image of triangle A after:  
a rotation of  $90^\circ$  clockwise about the origin,  
followed by  
a translation of  $\begin{pmatrix} -5 \\ -1 \end{pmatrix}$ .**

**Draw and label triangle B on the diagram. [4]**

**(b) Triangle C is an enlargement of triangle A.**

**Describe the enlargement fully.**

---

---

**[2]**

- 9 The diagram below shows a rectangle and a triangle. The perimeter of the rectangle is equal to the perimeter of the triangle.

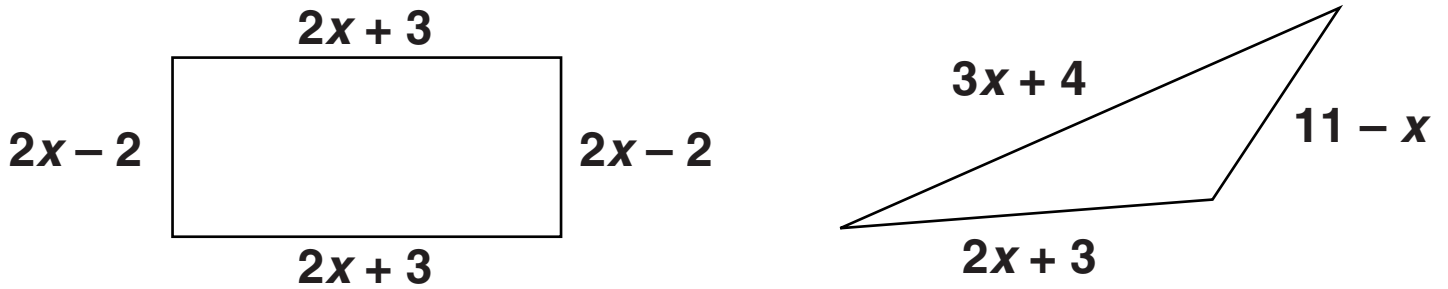

NOT TO SCALE

Find the length of the shortest side of the triangle.

Shortest side = \_\_\_\_\_ [5]

**BLANK PAGE**

- 10 A group of 60 students entered a general knowledge competition.  
The table below shows the distribution of their scores.

Score ( $s$ )	Frequency
$0 < s \leq 20$	5
$20 < s \leq 40$	10
$40 < s \leq 60$	19
$60 < s \leq 80$	14
$80 < s \leq 100$	12

- (a) Complete the following cumulative frequency table for this distribution. [1]

Score ( $s$ )	Cumulative frequency
$s \leq 20$	
$s \leq 40$	
$s \leq 60$	
$s \leq 80$	
$s \leq 100$	

**(b) On the grid below, draw a cumulative frequency graph to represent the distribution. [2]**

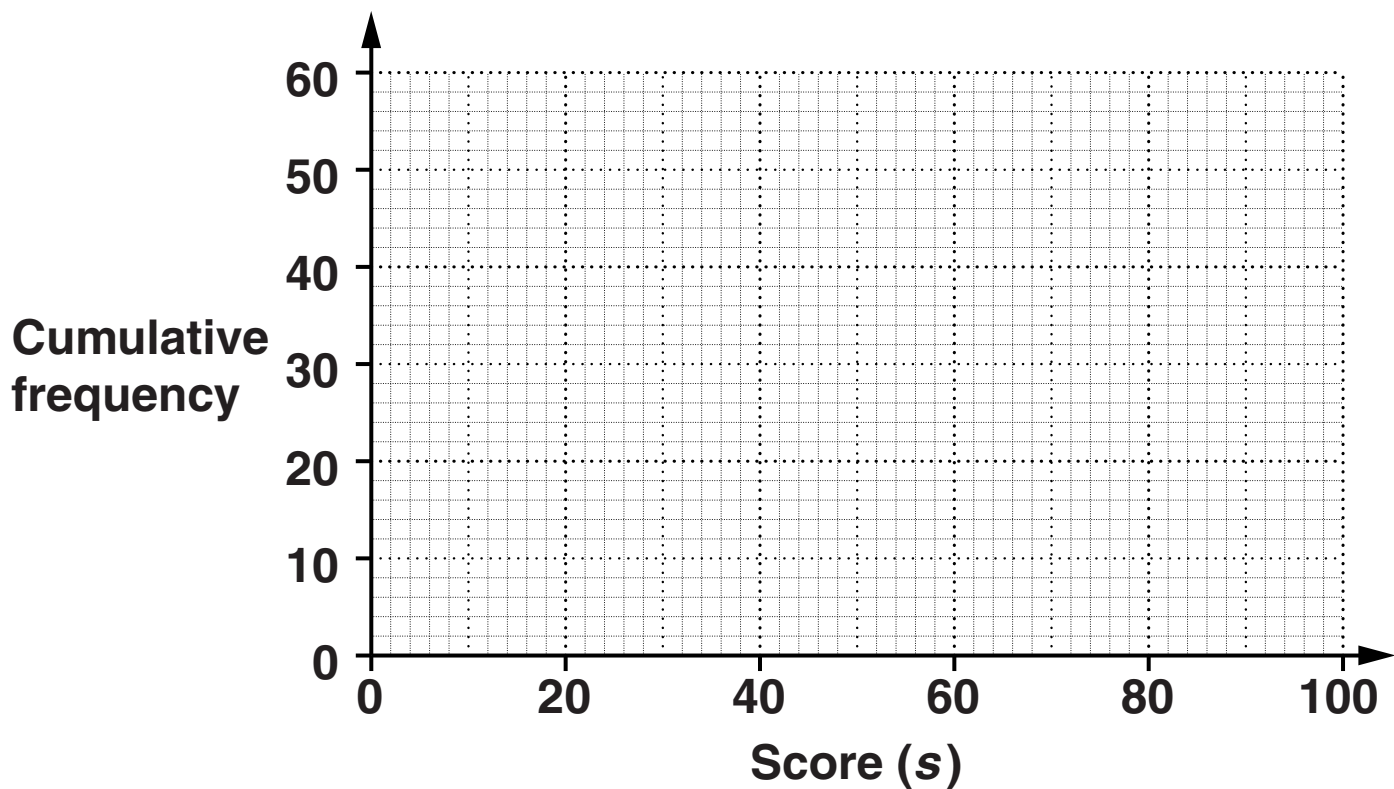

**(c) Students scoring MORE THAN 75 won a prize.  
Use the graph to estimate the number of students  
who won a prize.**

**(c) \_\_\_\_\_ [2]**

- 11 The table below shows the number of barrels of oil produced each day in some countries.

Country	Oil produced (barrels per day)
Russia	$1.01 \times 10^7$
Saudi Arabia	$9.76 \times 10^6$
USA	$9.06 \times 10^6$
China	$3.99 \times 10^6$

- (a) How many barrels per day were produced in the USA?  
Give your answer as an ordinary number.

(a) \_\_\_\_\_ [1]

- (b) How many more barrels per day were produced in Russia than in Saudi Arabia?

(b) \_\_\_\_\_ [2]



**(c) The production of one barrel per day is equivalent to approximately 50 tonnes of oil per year.**

**Estimate the number of tonnes of oil produced in China each year.**

**Give your answer in standard form.**

**(c) \_\_\_\_\_ tonnes [2]**

**12 A garden pond has a surface area of  $3 \text{ m}^2$ .  
The pond is a prism of constant depth  $60 \text{ cm}$ .**

**(a) (i) Calculate the volume, in  $\text{m}^3$ , of the pond.**

**(a)(i) \_\_\_\_\_  $\text{m}^3$  [2]**

**(ii) How many litres of water does the pond contain?**

**(ii) \_\_\_\_\_ litres [1]**

**(b) A scale model of the pond is made.  
The depth of the pond in the model is 6 cm.**

**(i) Find the surface area of the model pond.**

**(b)(i) \_\_\_\_\_ m<sup>2</sup> [3]**

**(ii) How many litres of water does the model pond contain?**

**(ii) \_\_\_\_\_ litres [1]**

**BLANK PAGE**

13 The graphs of  $y = -1$ ,  $y = x + 2$  and  $x + y = 3$  are drawn on the grid below.

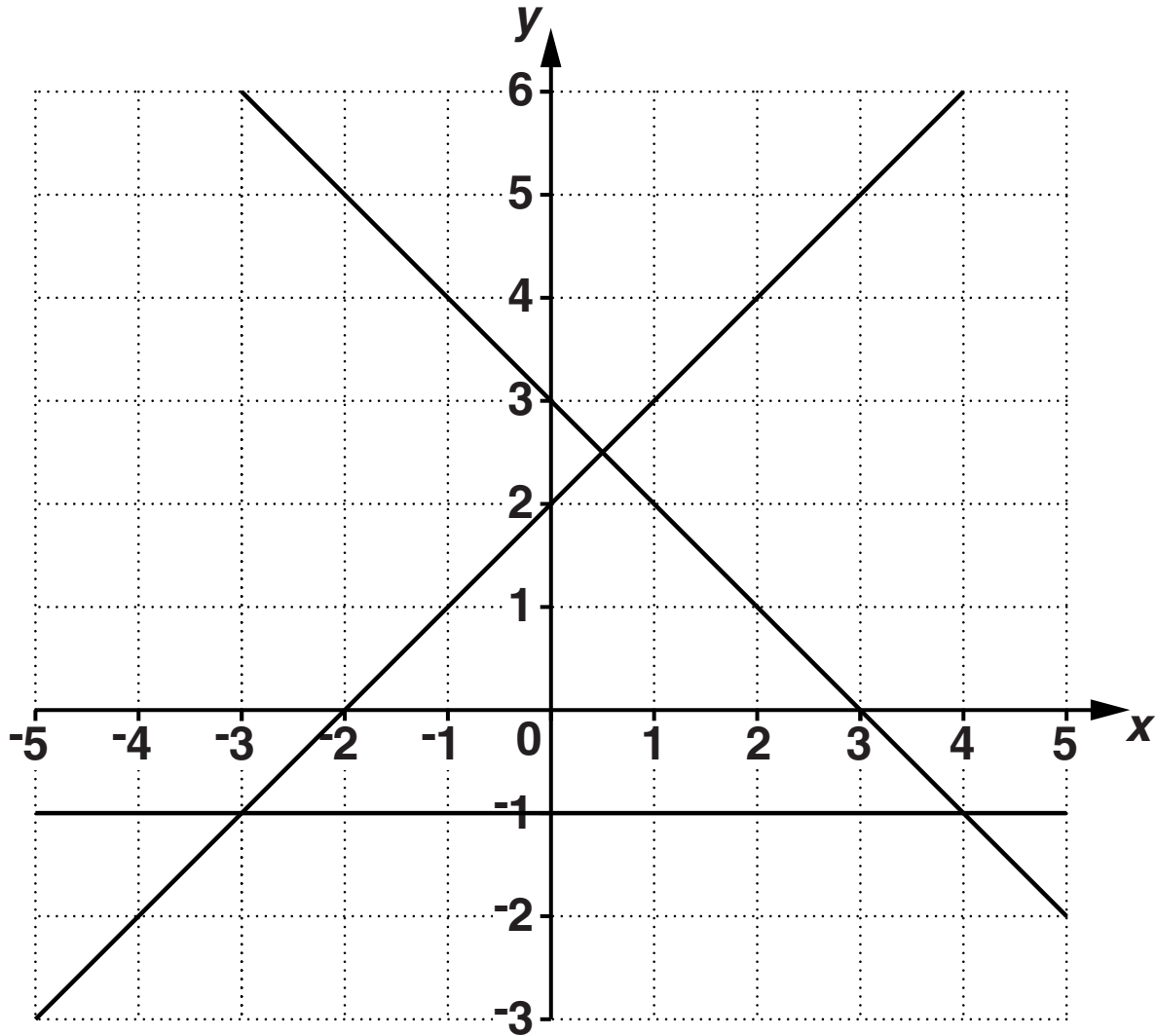

Show clearly the region R which satisfies all of these inequalities. [3]

$$y \geq -1$$

$$x + y \leq 3$$

$$y \geq x + 2$$

**14 Each statement opposite is sometimes true and sometimes false.**

**For each statement sketch a graph to show an example where it is true and an example where it is false.**

**The first one has been done for you. [3]**

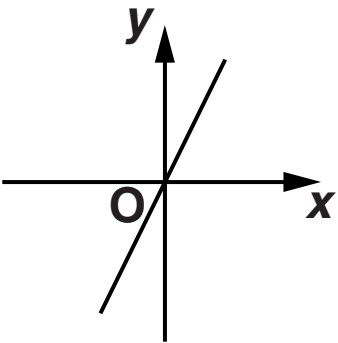
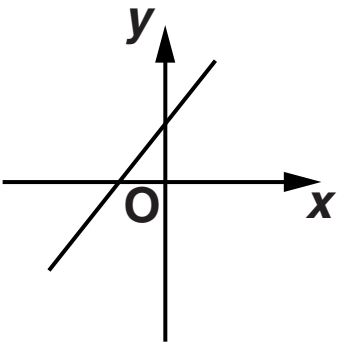
Statement	True	False
A straight line graph goes through the origin.		

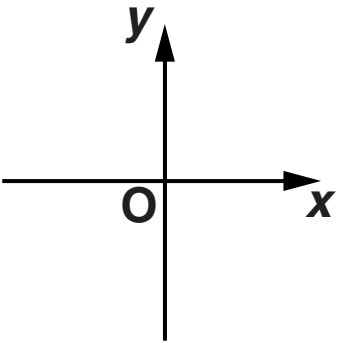
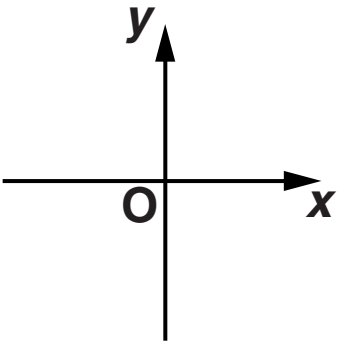
Statement	True	False
The gradient of a straight line graph is positive.		

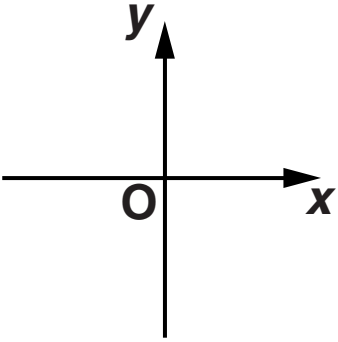
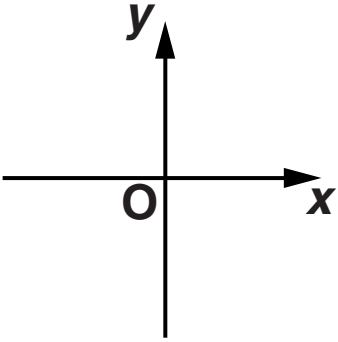
Statement	True	False
A quadratic equation $ax^2 + bx + c = 0$ has two positive solutions.		

**BLANK PAGE**



**15 A box contains 8 milk chocolates, 6 dark chocolates and 2 white chocolates.  
Varun takes a chocolate from the box at random and eats it.  
He then takes another chocolate at random and eats it.**

**Find the probability that Varun eats at least one dark chocolate.**

\_\_\_\_\_ [4]

16 (a) Solve.

$$\frac{3x-1}{5} = x-2$$

(a)  $x =$  \_\_\_\_\_ [3]

(b) Simplify.

$$\left(\frac{a^5}{a^9}\right)^{-2}$$

(b) \_\_\_\_\_ [2]

**(c) Express as a single fraction in its simplest form.**

$$\frac{4}{x-2} - \frac{5}{x+1}$$

**(c)** \_\_\_\_\_ **[3]**

17 OPQR is a parallelogram.

$\vec{OP} = \mathbf{a}$  and  $\vec{OR} = \mathbf{b}$ .

X and Y are the points on OQ such that  $OX = XY = YQ$ .  
This is shown on the following diagram.

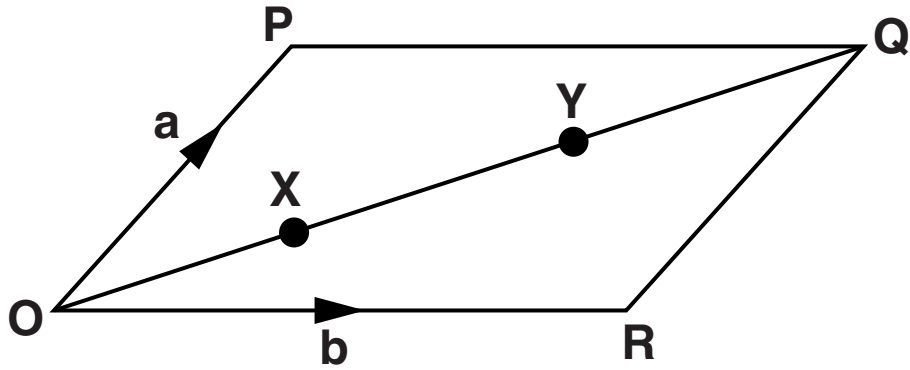

NOT TO SCALE

Find as simply as possible in terms of  $\mathbf{a}$  and  $\mathbf{b}$ ,

(a)  $\vec{OQ}$ ,

(a) \_\_\_\_\_ [1]

(b)  $\vec{PR}$ ,

(b) \_\_\_\_\_ [1]

(c)  $\overrightarrow{XY}$ ,

(c) \_\_\_\_\_ [1]

(d)  $\overrightarrow{XR}$ .

(d) \_\_\_\_\_ [2]

- 18 The diagram below shows a shape made from two squares and two right-angled triangles. The area of the smaller square is  $5 \text{ cm}^2$  and the area of the larger square is  $15 \text{ cm}^2$ .

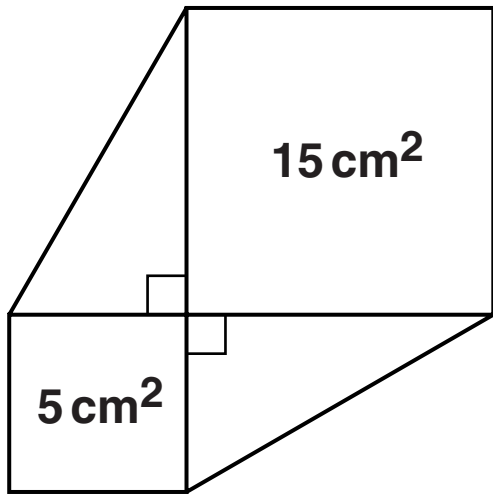

NOT TO SCALE

Work out the area of the complete shape.  
Give your answer in the form  $a + b\sqrt{c}$ , where  $c$  is as small as possible.

\_\_\_\_\_  $\text{cm}^2$  [4]

**19 Solve algebraically these simultaneous equations.**

$$y = 4x^2 - 9x - 1$$

$$y = 5 - 4x$$

$$x = \underline{\hspace{2cm}} \quad y = \underline{\hspace{2cm}}$$

$$x = \underline{\hspace{2cm}} \quad y = \underline{\hspace{2cm}} \quad [6]$$

**END OF QUESTION PAPER**

## **Copyright Information**

**OCR is committed to seeking permission to reproduce all third-party content that it uses in its assessment materials. OCR has attempted to identify and contact all copyright holders whose work is used in this paper. To avoid the issue of disclosure of answer-related information to candidates, all copyright acknowledgements are reproduced in the OCR Copyright Acknowledgements Booklet. This is produced for each series of examinations and is freely available to download from our public website ([www.ocr.org.uk](http://www.ocr.org.uk)) after the live examination series.**

**If OCR has unwittingly failed to correctly acknowledge or clear any third-party content in this assessment material, OCR will be happy to correct its mistake at the earliest possible opportunity.**

**For queries or further information please contact the Copyright Team, First Floor, 9 Hills Road, Cambridge CB2 1GE.**

**OCR is part of the Cambridge Assessment Group; Cambridge Assessment is the brand name of University of Cambridge Local Examinations Syndicate (UCLES), which is itself a department of the University of Cambridge.**

