

Surname	Centre Number	Candidate Number
Other Names		0



GCSE

4370/03



A14-4370-03

**MATHEMATICS – LINEAR
PAPER 1
FOUNDATION TIER**

A.M. WEDNESDAY, 5 November 2014

1 hour 45 minutes

**CALCULATORS ARE
NOT TO BE USED
FOR THIS PAPER**

ADDITIONAL MATERIALS

A ruler, a protractor and a pair of compasses may be required.

INSTRUCTIONS TO CANDIDATES

Use black ink or black ball-point pen.

Write your name, centre number and candidate number in the spaces at the top of this page.

Answer **all** the questions in the spaces provided.

Take π as 3.14.

INFORMATION FOR CANDIDATES

You should give details of your method of solution when appropriate.

Unless stated, diagrams are not drawn to scale.

Scale drawing solutions will not be acceptable where you are asked to calculate.

The number of marks is given in brackets at the end of each question or part-question.

You are reminded that assessment will take into account the quality of written communication (including mathematical communication) used in your answer to question 2(c).

For Examiner's use only		
Question	Maximum Mark	Mark Awarded
1.	12	
2.	7	
3.	4	
4.	11	
5.	6	
6.	4	
7.	3	
8.	4	
9.	6	
10.	3	
11.	6	
12.	6	
13.	3	
14.	3	
15.	6	
16.	7	
17.	5	
18.	4	
Total	100	

4370
030001

Formula List

Area of trapezium = $\frac{1}{2}(a + b)h$

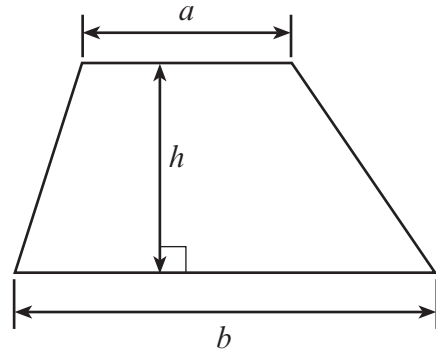

Volume of prism = area of cross-section \times length



1. (a) (i) Write down, in figures, the number fifty two thousand and four. [1]

.....
(ii) Write down, in words, the number 6 700 000. [1]

.....

(b) Using only the numbers in the following list,

36 37 47 53 56 44 81 34

write down

(i) two numbers that add up to 80, [1]

.....
(ii) the number which must be added to 46 to make 83, [1]

.....
(iii) a multiple of 8, [1]

.....
(iv) the square number that is also an odd number. [1]

.....

(c) Write 79 634

(i) correct to the nearest 100, [1]

.....
(ii) correct to the nearest 1000. [1]

.....

(d) Write down all the factors of 12. [2]

.....

.....

(e) A packet of paper costs £2.97. How many packets of paper can be bought for £15? [2]

.....

.....

.....

2. (a) Write down the value of the 7 in the number 12 762. [1]

.....

(b) Write down a prime number between 20 and 30. [1]

.....

(c) *You will be assessed on the quality of your written communication in this part of the question.*

Disha has £6.
She buys some pineapples at 80p each and has 40p left over.
How many pineapples did she buy?
You must show all your working.

[5]

.....
.....
.....
.....
.....
.....
.....
.....
.....
.....
.....
.....
.....
.....

3. The formula for the cost of hiring a skip is given below.

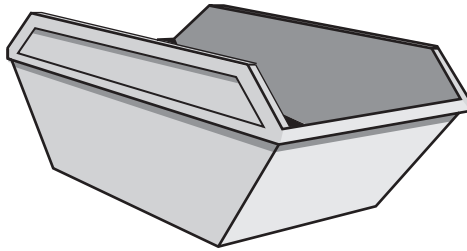

$$\text{cost of hire} = \text{number of days} \times \text{£40} + \text{delivery charge}$$

(a) Jac hired a skip for 5 days and the cost was £250.
What was the delivery charge?

[2]

.....

.....

.....

.....

(b) On another occasion, Jac hired a skip for £350 and the delivery charge was £30.
For how many days did he hire the skip?

[2]

.....

.....

.....

.....

.....

.....

.....

4370
03/00/05

4. At a sporting event, Rhian carried out a survey to find out from which continent each athlete had come. Her results are shown below.

Continent	Europe	Africa	Asia	The Americas	Australasia
Number of athletes	40	30	35	70	25

- (a) Draw a pictogram to represent the above information, using  to represent 20 athletes.

[4]

Europe	
Africa	
Asia	
The Americas	
Australasia	

- (b) On the centimetre squared paper on the next page, draw a bar chart to represent the above information. [4]

- (c) Write down the mode. [1]

.....

- (d) Find the probability that an athlete, chosen at random from this group, comes from Africa. [2]

.....

.....

.....

.....

Examiner only

4370
03/00/07

5. Three identical rectangles, each measuring 7 cm by 3 cm, are placed together to make the shape shown in the diagram.

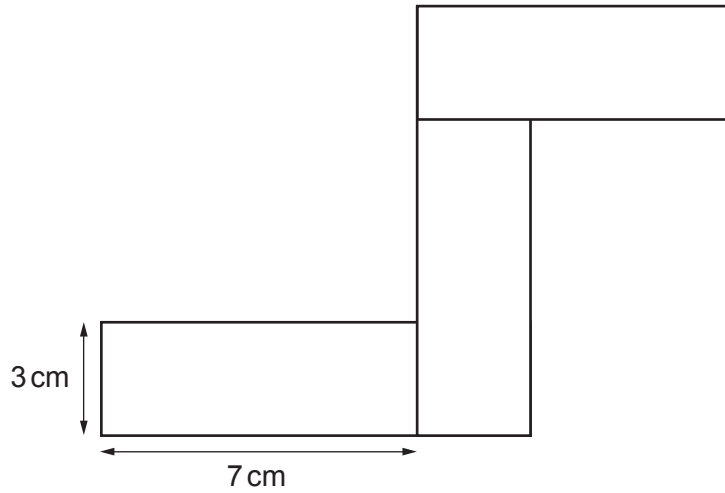

Diagram not drawn to scale

- (a) Calculate the perimeter of the shape.

[3]

.....

.....

.....

- (b) Calculate the area of the shape.
Write down the units of your answer.

[3]

.....

.....

.....

.....

6.

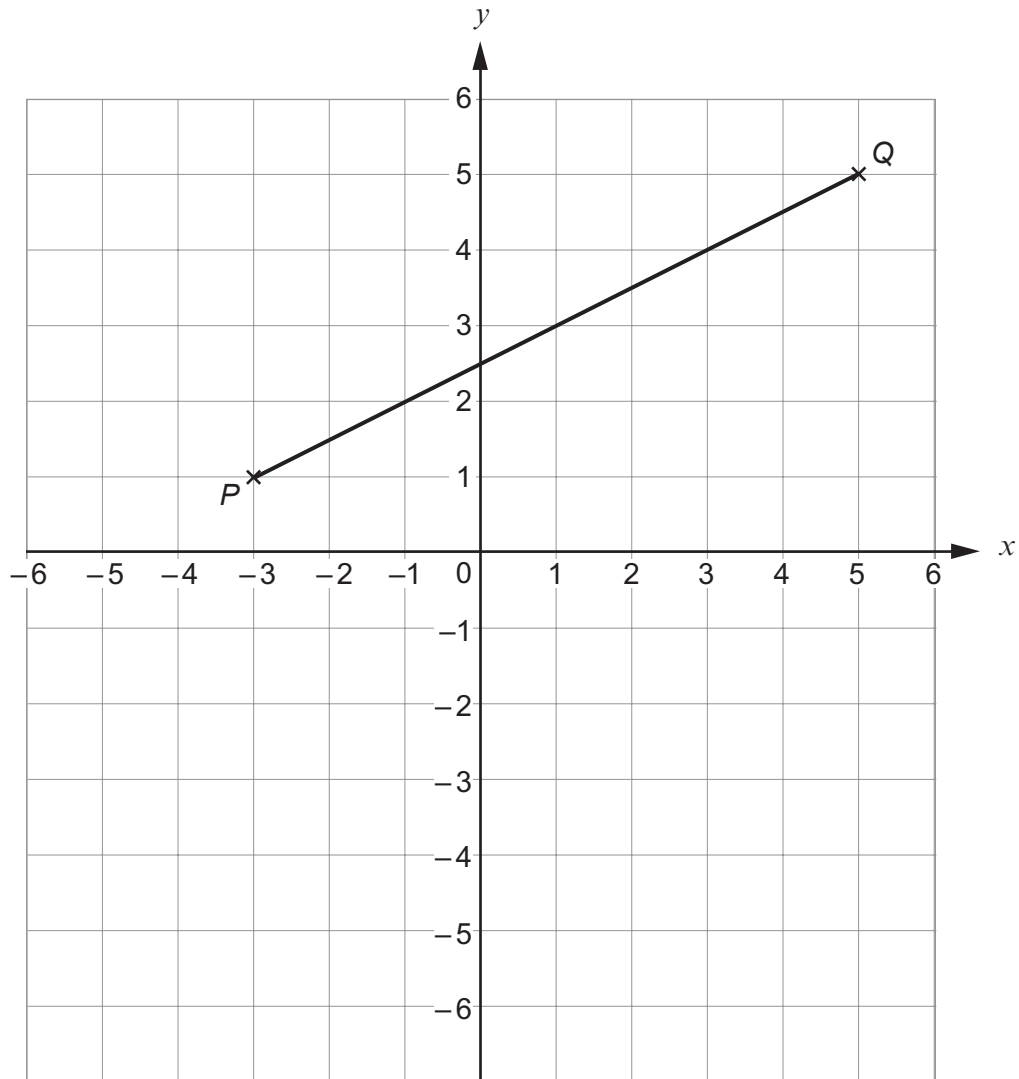

- (a) Write down the coordinates of the point P . [1]

(.....,)

- (b) The point R lies on the line PQ .
The y -coordinate of R is 4.
What is the x -coordinate of the point R ? [1]

x -coordinate =

- (c) The coordinates of the point $(1, 3)$ add up to 4.
Write down the coordinates of the point on PQ which add up to 1. [2]

(.....,)

7. Three children share 20 cubes.
Melanie takes 25% of the cubes.
John and Denise share the rest of the cubes.
John gets more cubes than Denise.

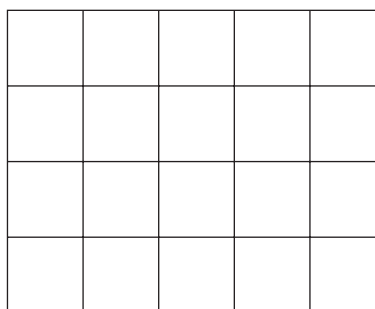

What is the greatest number of cubes that Denise could get?

[3]

.....

.....

.....

.....

.....

.....

8. Gayle buys 8 biros for £3.
Three of them are black.
The others are red.
Each red biro costs 45p.
What is the cost of one black biro?

[4]

.....

.....

.....

.....

.....

.....

.....

.....

.....

.....

9. (a) Simplify $4x - 2y - 3x + 5y$.

[2]

.....

.....

.....

(b) Solve $5t - 6 = 9$.

[2]

.....

.....

.....

(c) Find the value of $2p + 5q$ when $p = -3$ and $q = 2$.

[2]

.....

.....

.....

10. The sketch shows a triangular plot of land, with a church marked C , a school marked S and a bus stop marked B . The actual straight line distances between these places are also shown on the diagram.

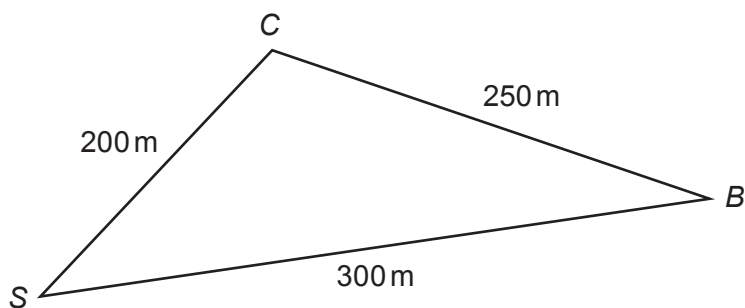

Diagram not drawn to scale

Using a scale of 1 cm to represent 25 m , construct a scale drawing of the plot of land. [3]

.....

.....

.....

11. In a game, a player rolls a coin onto a board marked out in squares. The squares on the board are coloured red, blue or green. If the coin lands entirely within one of these coloured squares the player wins a prize. Otherwise the player loses.

The table below shows the probabilities of the coin landing entirely within each coloured square.

Colour	Red	Blue	Green
Probability	0.13	0.14	0.04

- (a) What is the probability that a player wins a prize? [2]

.....

.....

.....

- (b) One day 200 people play this game. How many people would you expect to win a prize? [2]

.....

.....

.....

- (c) It costs 70p to play the game once. The prize for winning is £1.50. If the 200 people play the game once, how much profit do you expect the game to make? [2]

.....

.....

.....

.....

.....

.....

.....

.....

.....

.....

12. (a) $ABCD$ is a parallelogram with $\widehat{ADC} = 46^\circ$ and $\widehat{ACB} = 59^\circ$. Find the size of angle x .

[3]

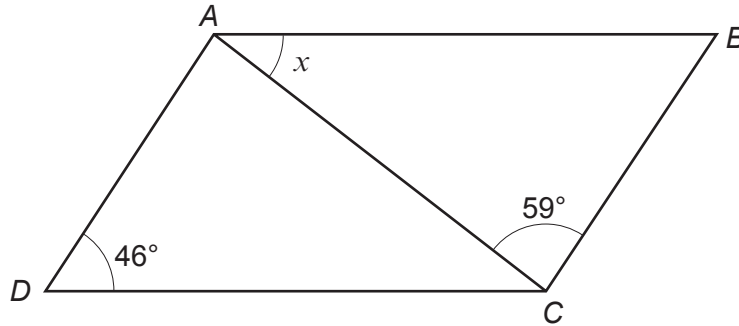

Diagram not drawn to scale

.....

.....

.....

$x = \dots\dots\dots^\circ$

- (b) Find the size of angle y .

[3]

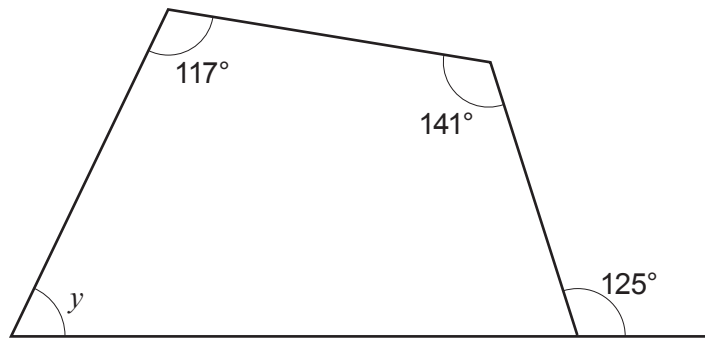

Diagram not drawn to scale

.....

.....

.....

$y = \dots\dots\dots^\circ$

13. The following is part of a train timetable from Bangor to Chester.

Bangor	11:07	12:24	13:07
Llandudno Junction	11:25	12:42	13:25
Colwyn Bay	11:31	12:48	13:31
Rhyl	11:41	12:59	13:41
Prestatyn	11:47	13:05	13:47
Flint	12:00	13:18	14:00
Chester	12:19	13:32	14:19

- (a) Bob catches the 11:31 train from Colwyn Bay.
When should the train arrive at Prestatyn?

[1]

.....

- (b) Mary catches the 13:25 train at Llandudno Junction.
How long should it take her to get to Chester?

[2]

.....

.....

.....

14. Express 240 as a product of prime numbers in index form.

[3]

.....

.....

.....

.....

.....

.....

15.

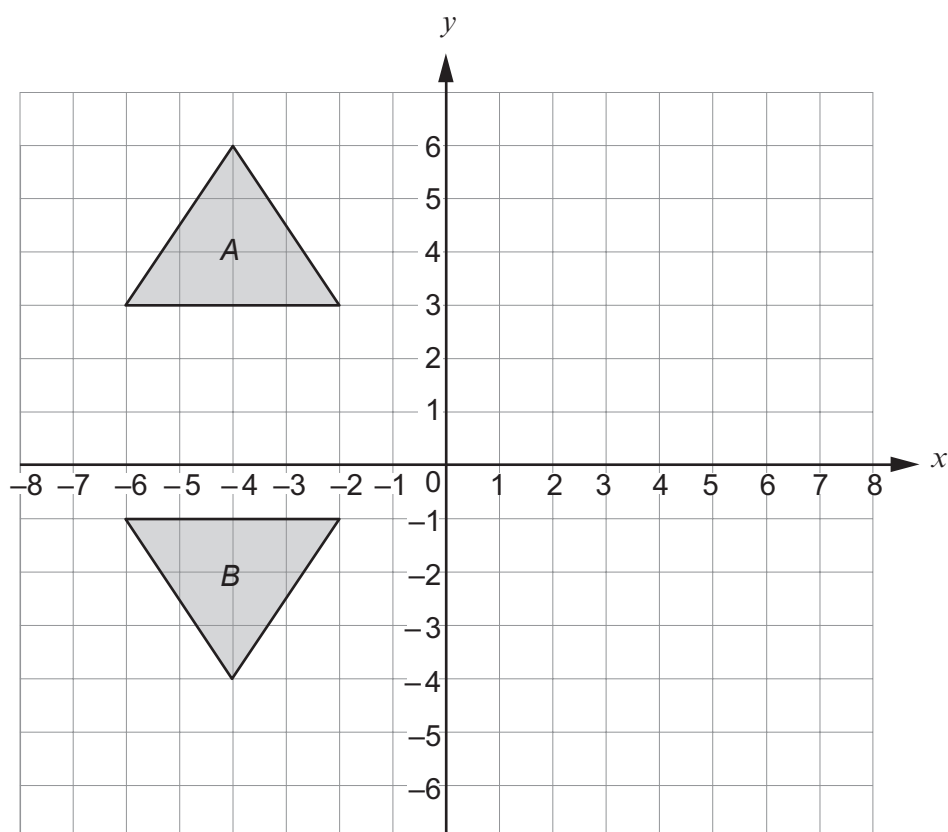

The diagram shows the transformation of triangle *A* to triangle *B*.

- (a) Fully describe a possible transformation of triangle *A* to triangle *B*.

[2]

.....

.....

.....

.....

- (b) Rotate triangle *A* through 90° clockwise about the origin.
Label your answer *C*.

[2]

- (c) Draw an enlargement of the shape below, using a scale factor of 2.

[2]

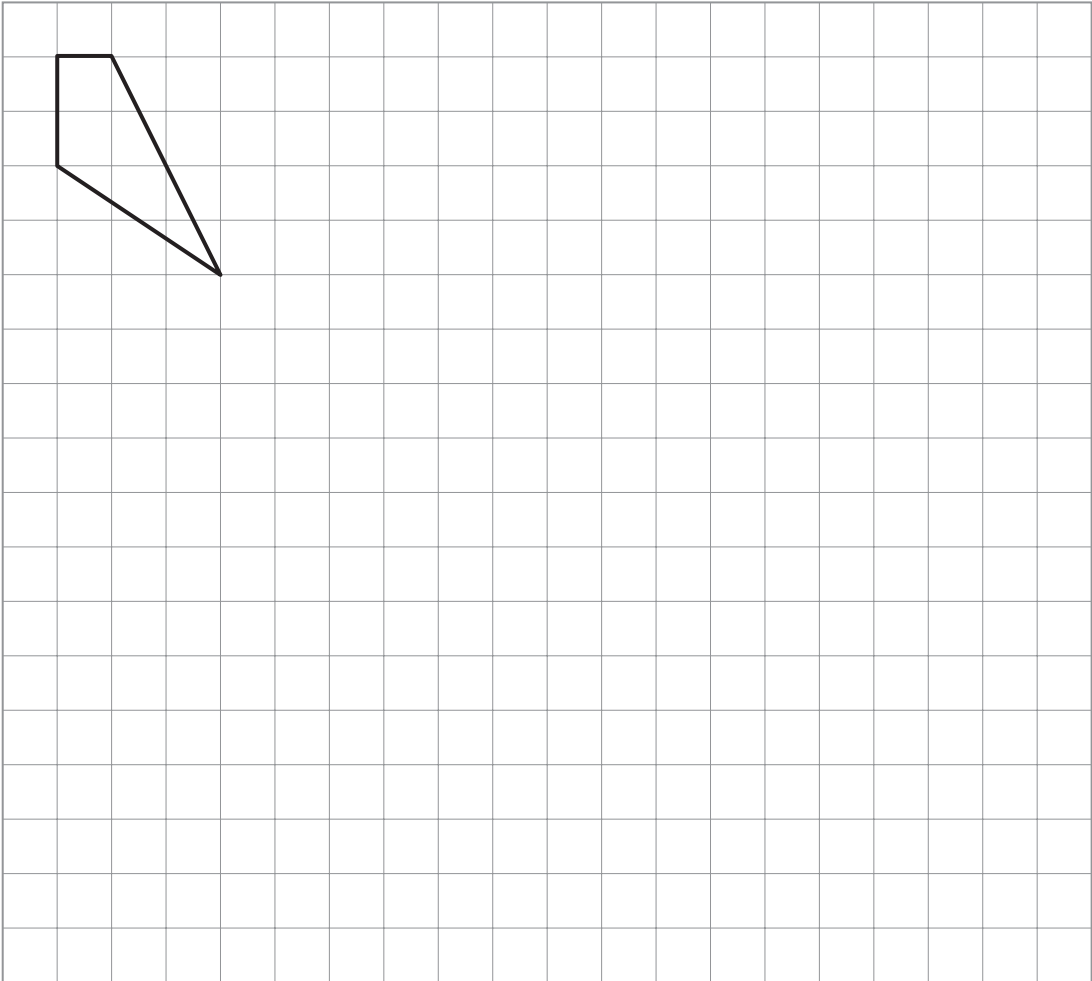
Examiner
only

16. Sophie is going on holiday.

(a) Sophie travels a distance of 35 miles in 2 hours 30 minutes through busy traffic.

Calculate Sophie's average speed, in miles per hour.

[3]

.....

.....

.....

.....

.....

.....

(b) Sophie's luggage weighs 22lb.



Approximately how much does her luggage weigh in kg?

[1]

.....

.....

.....

.....

17. (a) Solve $5x - 12 = 3(x + 6)$.

[3]

.....

.....

.....

.....

.....

(b) Solve the inequality $9x + 5 < 77$.

[2]

.....

.....

.....

.....

.....

.....

18. The diagram shows a rectangle $ABCD$.

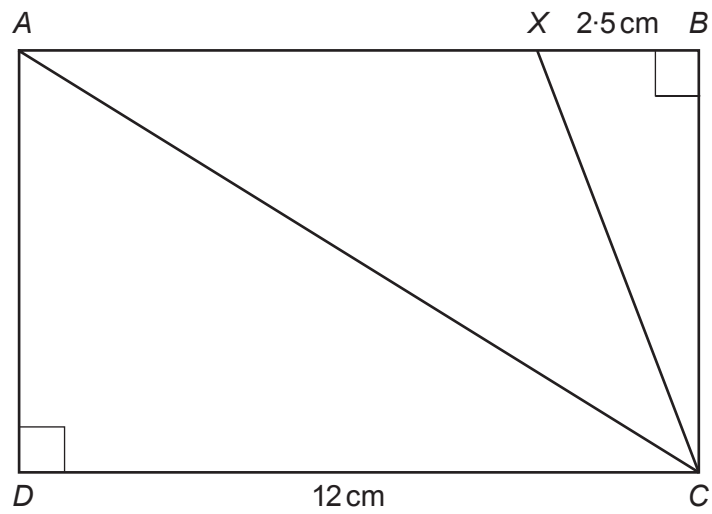

Diagram not drawn to scale

Given that $XB = 2.5\text{ cm}$, $DC = 12\text{ cm}$ and the area of triangle ADC is 60 cm^2 , calculate the area of triangle XBC . [4]

.....

.....

.....

.....

.....

.....

.....

.....

.....

.....

.....

.....

.....

.....

.....

.....

.....

.....

.....

.....

.....

.....

END OF PAPER

BLANK PAGE

BLANK PAGE