



General Certificate of Secondary Education
2017

Centre Number

| | | | | |
|--|--|--|--|--|
| | | | | |
|--|--|--|--|--|

Candidate Number

| | | | |
|--|--|--|--|
| | | | |
|--|--|--|--|

Mathematics

Unit T5 Paper 2
(With calculator)
Foundation Tier



[GMT52]

GMT52

FRIDAY 2 JUNE, 10.45am – 11.45am

TIME

1 hour.

INSTRUCTIONS TO CANDIDATES

Write your Centre Number and Candidate Number in the spaces provided at the top of this page.

You must answer the questions in the spaces provided.

Do not write outside the boxed area on each page, on blank pages or tracing paper.

Complete in black ink only. **Do not write with a gel pen.**

Answer **all seventeen** questions.

All working should be clearly shown in the spaces provided. Marks may be awarded for partially correct solutions.

You **may** use a calculator for this paper.

INFORMATION FOR CANDIDATES

The total mark for this paper is 50.

Figures in brackets printed down the right-hand side of pages indicate the marks awarded to each question or part question.

Functional Elements will be assessed in this paper.

Quality of written communication will be assessed in Question 16

You should have a calculator, ruler, compasses and a protractor.

The Formula Sheet is on page 2.

10605



16GMT5201

Formula Sheet

Area of trapezium = $\frac{1}{2}(a + b)h$

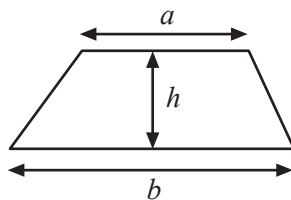

Volume of prism = area of cross section \times length

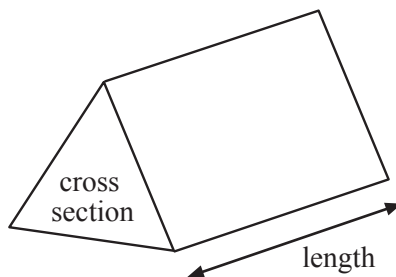

1 Draw the reflection of the shape in the mirror line.

Mirror line

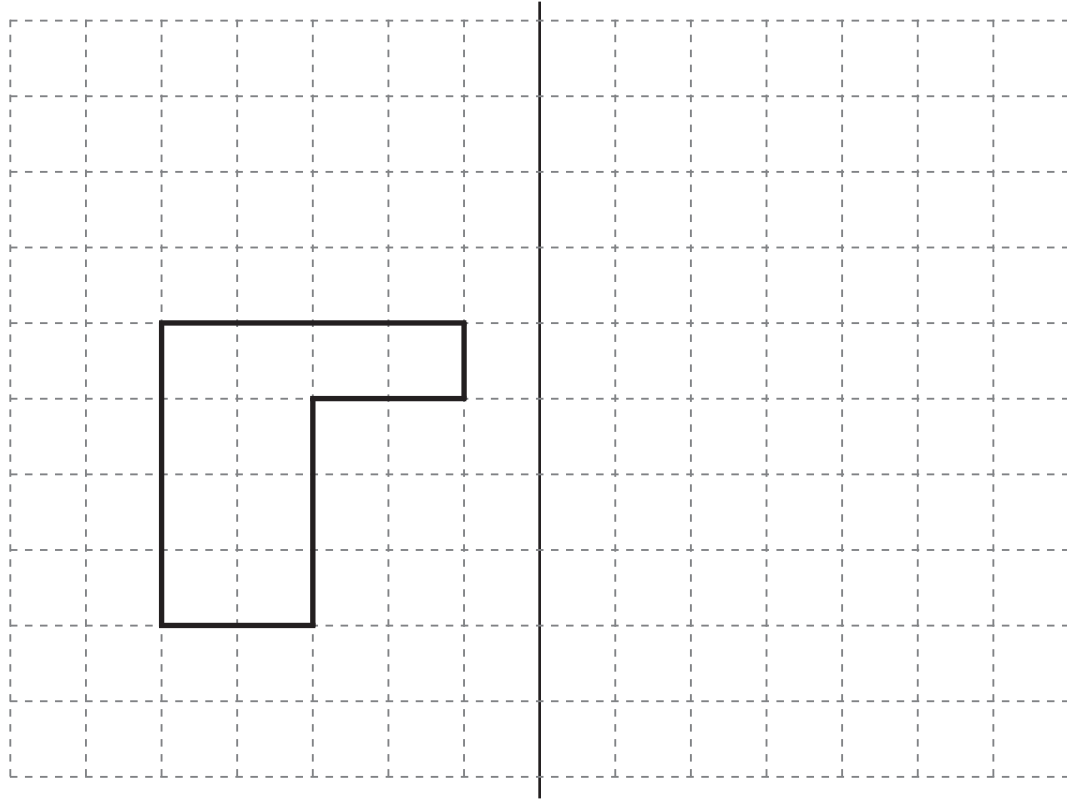

[2]



2 Maura works 36 hours each week and earns £8.50 per hour.

(a) How much does she earn each week?

Answer £ _____ [2]

(b) How much does she earn in a year (take 1 year as 52 weeks)?

Answer £ _____ [1]

(c) How much does she earn each month on average?

Answer £ _____ [1]



3

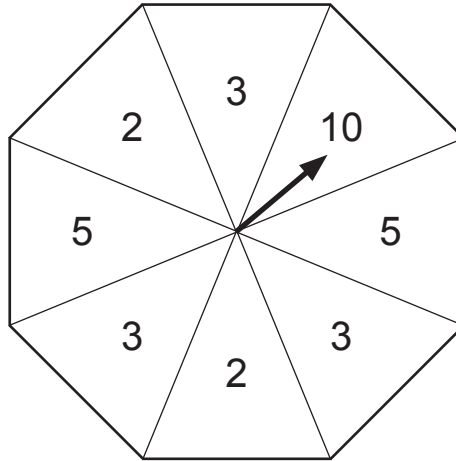

The fair spinner has the numbers 2, 3, 5, 10 as shown. It is spun once.

(a) Which number is the arrow most likely to point to?

Answer _____ [1]

(b) What is the probability of the arrow pointing to a factor of 30?

Answer _____ [1]

(c) What is the probability of the arrow pointing to a square number?

Answer _____ [1]

(d) What is the probability of the arrow pointing to an even number?

Answer _____ [1]

[Turn over



4 To change temperatures from Fahrenheit to Celsius:

Take away 32, then multiply by 5, then divide by 9

(a) Change 50° Fahrenheit to $^{\circ}$ Celsius.

Answer _____ $^{\circ}$ Celsius [2]

(b) Change 32° Fahrenheit to $^{\circ}$ Celsius.

Answer _____ $^{\circ}$ Celsius [1]

(c) Which is the bigger drop in temperature, 10° Fahrenheit or 10° Celsius?
Explain your answer.

Answer _____ because _____ [2]



5 A television costs £270 plus VAT.

VAT is charged at 20%.

Calculate the VAT charged.

Answer £ _____ [2]

6 A baby elephant weighs 198 lbs.

How many kilograms is this?

Answer _____ kg [2]



7 (a) Calculate the volume of this CD case.

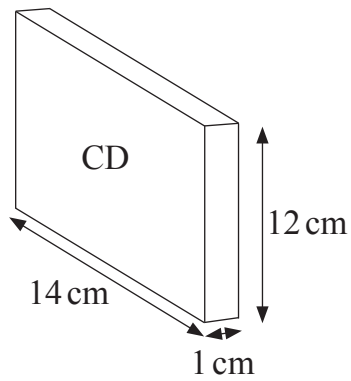

Answer _____ [2]

(b)

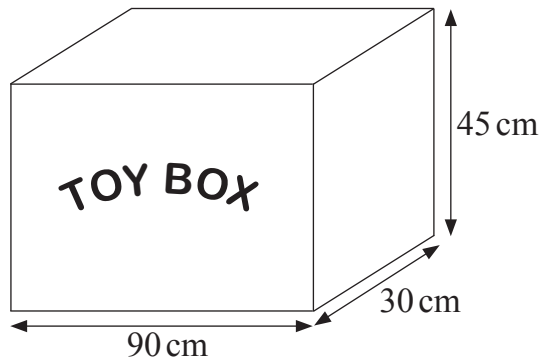

Calculate the total surface area of the **vertical** sides of this toy box, as shown.

Answer _____ cm² [2]



8 Areas of land are measured in either hectares or acres.

(a) Use the values given in the table to draw a conversion graph.

[3]

| | | | |
|-----------------|---|----|-----|
| Area (acres) | 0 | 50 | 200 |
| Area (hectares) | 0 | 20 | 80 |

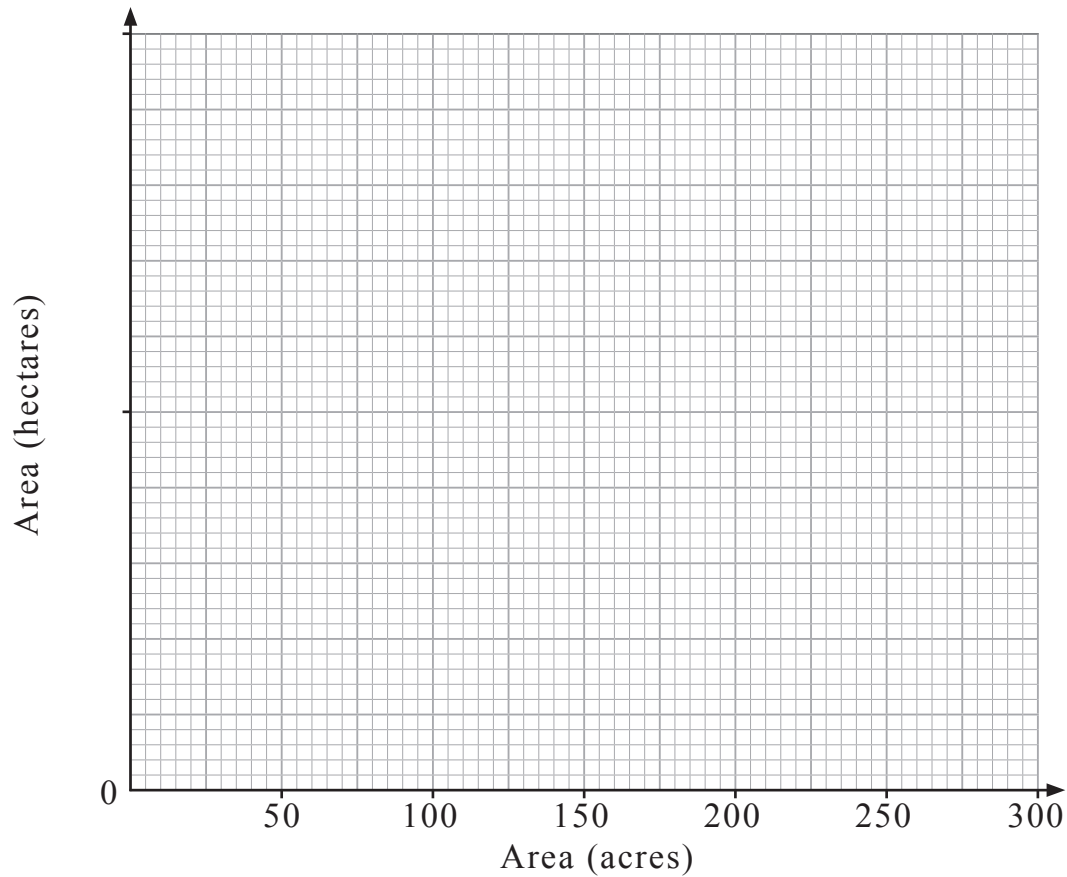

(b) Use your graph to find the number of hectares equivalent to 180 acres.

Answer _____ hectares [1]

[Turn over



- 9 (a) Lucy says that the probability of her getting a car for her 18th birthday is $\frac{3}{2}$
Explain what is wrong with Lucy's statement.

[1]

- (b) Lucy phones Tom. The probability that the phone line is busy is 0.26
What is the probability that it is not busy?

Answer _____ [1]

- 10 Colin works as a barman. He is paid £9.20 per hour and receives tips.

Last week the tips and his pay for 28 hours totalled £320.40

How much money did he receive in tips?

Answer £ _____ [3]



11 Cathy can buy either a 16GB memory stick or a 64GB memory stick.

The memory sticks are coloured black, red, yellow or green.

(a) Write down the size and colour of all the different memory sticks that Cathy can buy.

[2]

(b) Cathy bought one of each type of memory stick.

She gives one to her friend Jill.

What is the probability that this is a yellow 16GB memory stick?

Answer _____ [1]

12 What is the sum of all the fractions of the form $\frac{N}{5}$ where N is a whole number less than 5?

Answer _____ [2]

[Turn over



13 Rewrite $p + 8 = 6 - q$ to make q the subject.

Answer $q =$ _____ [2]

14 A coach travels 140 miles in 2 hours 30 minutes.

Calculate the average speed.

Answer _____ mph [3]



- 15 Ben observes whether cars turn right or left at a T junction. He records the number of cars that come to the junction and the number that turn left.

| | | | | |
|-------------------------------|----|----|----|-----|
| Number of cars observed | 10 | 20 | 50 | 100 |
| Number of cars that turn left | 4 | 13 | 33 | 72 |

- (a) What is the relative frequency of cars turning left after 50 observations?

Answer _____ [1]

- (b) What is the best estimate for the probability that a car will turn left at this junction?

Answer _____ [1]

- (c) In one week 580 cars come to this junction.

Estimate how many turn **right**.

Answer _____ [2]

[Turn over



Quality of written communication will be assessed in this question.

- 16 The six angles of two different triangles are placed in order of decreasing size. Two of the angles are unknown.

The sizes of the angles are:

118° 82° 78° 46° x° y°

What is the size of the smallest angle?

Answer _____ [2]



17 Adam, Bob and Chris have 18 marbles in total.

Bob gives 5 to Chris. Chris gives 3 to Adam. Adam gives 2 to Bob.

They now have the same number of marbles each.

How many marbles did Bob have to begin with?

Answer _____ [2]

THIS IS THE END OF THE QUESTION PAPER



DO NOT WRITE ON THIS PAGE

| For Examiner's use only | |
|-------------------------|-------|
| Question Number | Marks |
| 1 | |
| 2 | |
| 3 | |
| 4 | |
| 5 | |
| 6 | |
| 7 | |
| 8 | |
| 9 | |
| 10 | |
| 11 | |
| 12 | |
| 13 | |
| 14 | |
| 15 | |
| 16 | |
| 17 | |

| | |
|--------------------|--|
| Total Marks | |
|--------------------|--|

Examiner Number

Permission to reproduce all copyright material has been applied for.
In some cases, efforts to contact copyright holders may have been unsuccessful and CCEA will be happy to rectify any omissions of acknowledgement in future if notified.

10605/6



16GMT5216